



MODEL NO. 01.1815.A00 LED Folding Directional Arrow

General Information:

The LED Folding Directional Arrow alerts traffic in the direction they need to follow. The Arrow comes with accessory power adaptor plug. The power adaptor plug has a lighted on/off power switch and a momentary switch to change the pattern. To change the pattern, momentarily press the switch, each time the switch is pressed it will advance to the next pattern. The LED Arrow has four flash patterns from which to choose: Left Arrow - Right Arrow - Center-Out - Wig-wag.

Product Specifications:

Optimum Operation Voltage: +13.8 VDC
Operating Current: 2 amp max
Recommended Fuse: 5 amp

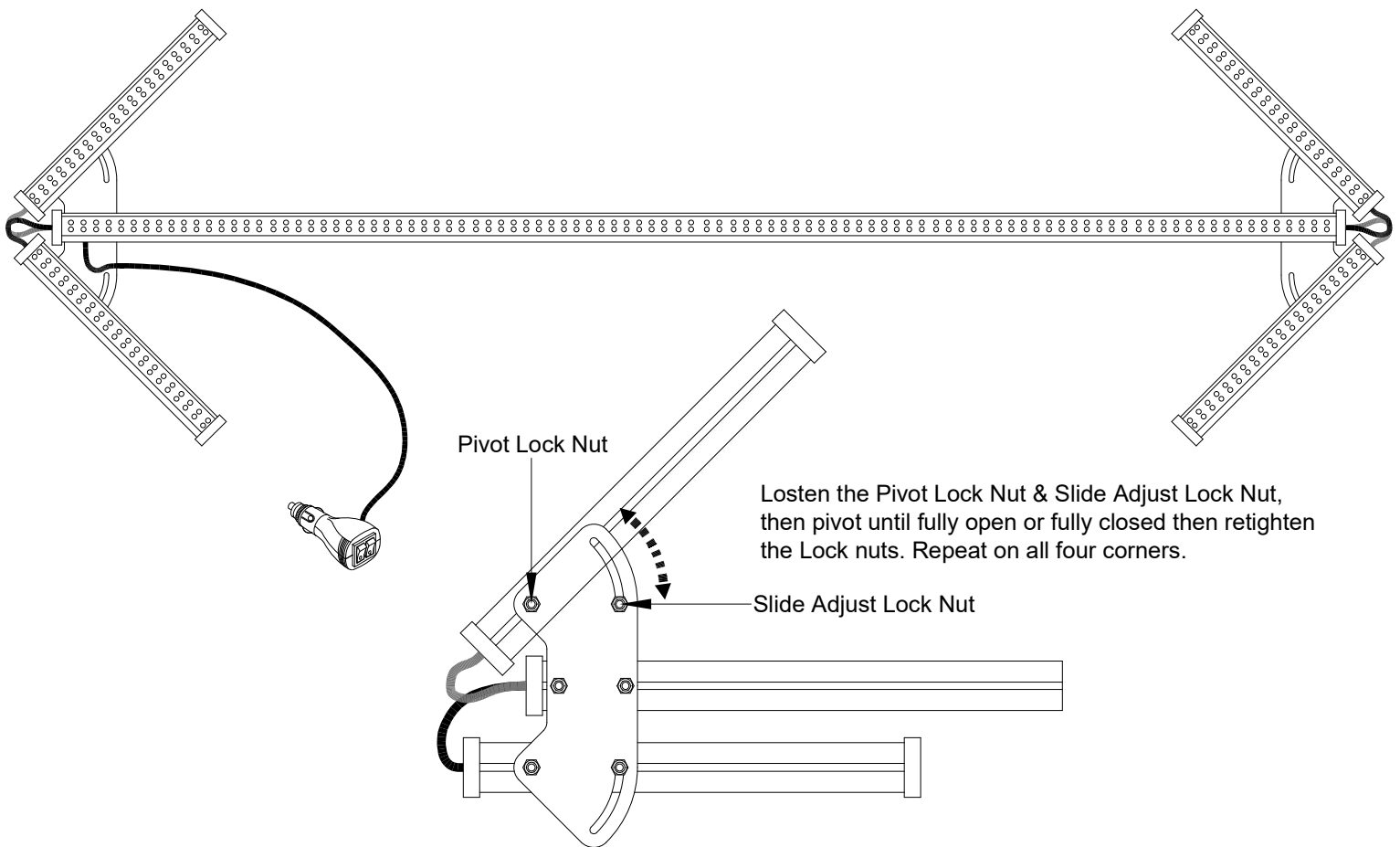

Installation Instructions

Slide the hex bolts provided into the t-slot as shown in the diagram. The light can be mounted using the bottom or rear t-slots. Always mount with the bottom t-slot down, This is to allow any moisture that enters the light housing to drain properly.

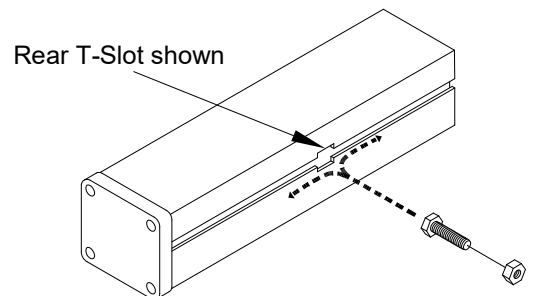

PRODUCTS COMPANY • 804 East Hwy. 248 • Cassville, MO 65625
U.S. and Canada Toll Free Numbers • Phone: 800-641-4098 FAX: 800-526-1240
E-mail: sales@able2products.com WEB: www.able2products.com

LIMITED WARRANTY

Able 2 Products Company warrants each new product (except bulbs, strobe tubes, strobe power supplies and LED lights) to be free from defects in material and workmanship for a period of two years from the date of purchase. During this warranty period, the obligation of Able 2 is limited to repairing or replacing, as Able 2 may elect, any part or parts, which after examination by Able 2 are determined to be defective, when they are delivered pre-paid. This limited warranty does not cover travel expense, the cost of specialized equipment for gaining access to the product, or labor charges for the removal and re-installation of the product.

Able 2 Products Company shall not be liable for incidental or consequential damages, including but not limited to: Loss of use of vehicle, Rental of substitute vehicle, Loss of time, Loss of work, Inconvenience, Transportation expenses, Telephone, Lodging, Loss of revenue, Loss of and/or damage to personal property for or arising out of breach of any express or implied warranty of its products.

Use of lamp or other electrical load of a wattage higher than installed or recommended by the factory, or use of inappropriate or inadequate wiring or circuit protection causes this limited warranty to become void. Able 2 Products Company will in no way be liable for any loss of profits or any indirect or consequential damages arising out of any such defect in material and workmanship whether loss is due to negligence or breach of warranty. This limited warranty does not apply to shipping damage, accident, alteration, tampering, misuse or abuse and unauthorized service.

This limited warranty is expressly in lieu of all other express or implied warranties, including the implied warranty of merchantability and the implied warranty of fitness for a particular purpose, and of all other obligations or liabilities on the part of Able 2 Products Company. There are no warranties, unless expressed in authorized Able 2 literature, which extend beyond the description of the face hereof. No dealer, distributor, employee, or representative of the company is authorized to change this warranty in any way or to grant any other warranty.

WARRANTY PERIODS

11, 12 & 13 Series LED Products*	2 Years
*11.8400 Series LED Lights	1 Year
*12 Series Covert LEDs	1 Year
10 Series LED Lights	1 Year
09 Zoom Lite / 06 Series LED Lights	1 Year
All Other Products EXCEPT Bulbs (under normal use)	1 Year

NOTE: Halogen and Incandescent Bulbs are not covered by warranty.

PRODUCT RETURNS

Merchandise returned under warranty shall be subject to factory inspection and repaired, replaced or credited at the option of Able 2 Products Company, Inc. Customer negligence will VOID warranty. Return authorization is required.

If a product must be returned, contact our factory by calling 1-800-641-4098 to obtain a Return Authorization Number (RA) before you ship the product. Our customer service specialists will ask for the model number of the item, the reason for the return, a description of any problems to repair, and whether you prefer a replacement, exchange, or credit.

A packing slip should be included with all shipments listing the sender's name, address, daytime phone number and description of defect. Enclose the packing slip, RA Number and address inside the shipping carton.

Use the following guidelines for addressing your package. Customer returns are occasionally delayed because return package addresses do not meet the required Post Office or delivery service standards and are not deliverable. A proper address will ensure that your return items reach us in a timely manner. Your product will be restored to first-rate operating condition or replaced with a new part, and returned pre-paid.

Returns and other mail via U.S. Postal Service:

Able 2 Products Company
P.O. Box 543
Cassville, MO 65625-0543

Returns via UPS or other delivery service:

Able 2 Products Company
804 East Highway 248
Cassville, MO 65625

Able 2
PRODUCTS COMPANY

January 2022