

# SHO-ME®

## The **SHO-ME®** Black Rack

Installation instructions for Model No.'s  
07.0200, 07.0300, 07.0400

### General:

The purpose of the SHO-ME **Black Rack** is to house and maintain radio, siren, and switching systems of an emergency vehicle without interference to the driver or air bag deployment.

### Instructions

1. Assemble mounting arms to base using bolts and nuts supplied. **DO NOT TIGHTEN YET.**
2. Mount electronic equipment to mounting arms and adjust mounting arms at the base to fit equipment.
3. Now tighten bolts and nuts on base to secure mounting arms.
4. Mount **Black Rack** securely to floor of vehicle using nuts, bolts and lock washers. If not possible, use self tapping screws, or see note below.

### Note

There are custom "no holes to drill" kits available for the Ford Crown Victoria and the Chevrolet Lumina. These kits allow you to mount the Black Rack on the center hump using existing seat bracket bolts.

**NOTE: THESE ARE NOT DESIGNED TO FIT THE 07.0200**

07.0200

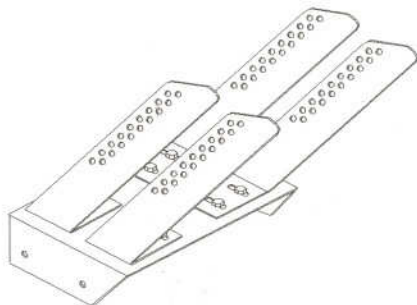

07.0300

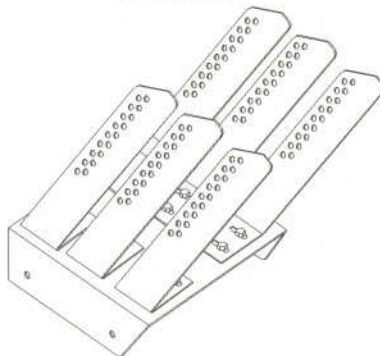

07.0400

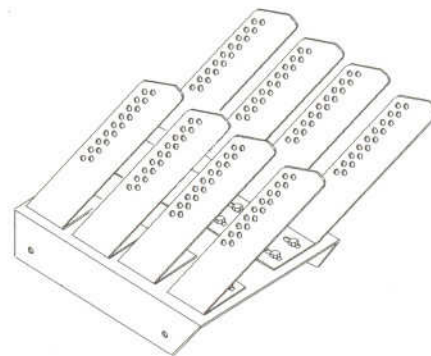

**PRODUCTS COMPANY • 804 East Hwy. 248 • Cassville, MO 65625**  
**U.S. and Canada Toll Free Numbers • Phone: 800-641-4098 FAX: 800-526-1240**  
**E-mail: sales@able2products.com WEB: www.able2products.com**

## LIMITED WARRANTY

Able 2 Products Company warrants each new product (except bulbs, strobe power supplies and strobe tubes) to be free from defects in material and workmanship for a period of two years from the date of purchase. During this warranty period, the obligation of Able 2 is limited to repairing or replacing, as Able 2 may elect, any part or parts, which after examination by Able 2 are determined to be defective, when they are delivered pre-paid. This limited warranty does not cover travel expense, the cost of specialized equipment for gaining access to the product, or labor charges for the removal and re-installation of the product.

Able 2 Products Company shall not be liable for incidental or consequential damages, including but not limited to: Loss of use of vehicle, Rental of substitute vehicle, Loss of time, Loss of work, Inconvenience, Transportation expenses, Telephone, Lodging, Loss of revenue, Loss of and/or damage to personal property for or arising out of breach of any express or implied warranty of its products.

Use of lamp or other electrical load of a wattage higher than installed or recommended by the factory, or use of inappropriate or inadequate wiring or circuit protection causes this limited warranty to become void. Able 2 Products Company will in no way be liable for any loss of profits or any indirect or consequential damages arising out of any such defect in material and workmanship whether loss is due to negligence or breach of warranty. This limited warranty does not apply to shipping damage, accident, alteration, tampering, misuse or abuse and unauthorized service.

This limited warranty is expressly in lieu of all other express or implied warranties, including the implied warranty of merchantability and the implied warranty of fitness for a particular purpose, and of all other obligations or liabilities on the part of Able 2 Products Company. There are no warranties, unless expressed in authorized Able 2 literature, which extend beyond the description of the face hereof. No dealer, distributor, employee, or representative of the company is authorized to change this warranty in any way or to grant any other warranty.

## PRODUCT RETURNS

If a product must be returned, contact our factory by calling 1-800-641-4098 to obtain a Return Authorization Number (RA) before you ship the product. Write the RA Number clearly on the package and return it to Able 2 Products Company, P.O. Box 543, 804 E. Hwy. 248, Cassville, MO 65625-0543. A packing slip should be included with all shipments listing the sender's name, address, daytime phone number and description of defect. Your product will be put in first-class operating condition or replaced with a new part, and returned pre-paid.

**WARRANTIES:** Strobe Power Supplies ----- 5 years  
All other products (EXCEPT Bulbs) --- 2 years (Under normal use)  
Note: Strobe Tubes - 1 Year Warranty (Under normal use)  
Halogen and Incandescent bulbs are not covered by warranty.



**PRODUCTS COMPANY** • 804 East Hwy. 248 • Cassville, MO 65625  
U.S. and Canada Toll Free Numbers • Phone: 800-641-4098 FAX: 800-526-1240  
E-mail: [sales@able2products.com](mailto:sales@able2products.com) WEB: [www.able2products.com](http://www.able2products.com)